



**Un!ca**  
**ADAR**

The Unica full extension concealed runner combines Smove decelerated closing action with both traditional opening and Push self-opening for handle less furniture. The fully integrated operating system is completely mechanical and therefore does not require a power source.

- The runner is available in two versions:
- fixed to the drawer by locating pin (page 12 and 13)
  - fixed to the drawer by clip (page 14 and 15)



**OPENING WITHOUT HANDLE**

Push the frontal to open the drawer.



The drawer opens approximately 5 - 10 cm.



Open the drawer to access the inner space.



Open drawer.



Closing with decelerating effect.



**OPENING WITH HANDLE**

Pull the handle to open the drawer.



Open drawer.



Closing with decelerating effect.



**Fixing full-extension runner on cabinet side**

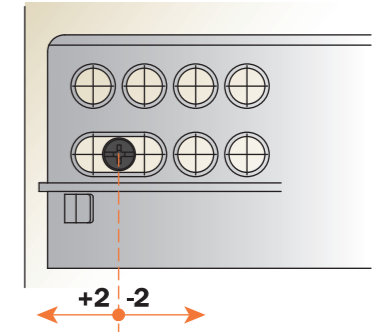
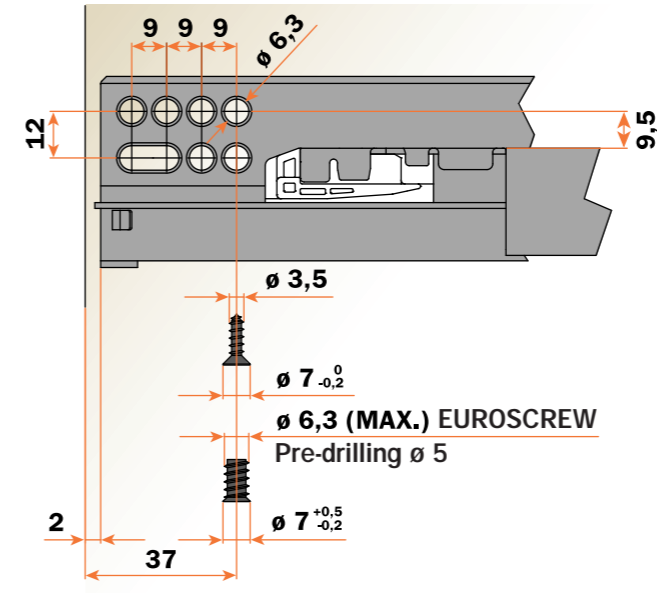

The oval slot allows the easy alignment of drawer frontals particularly in multi drawer and Push applications.

**Drilling positions for runner on cabinet side Full-extension**

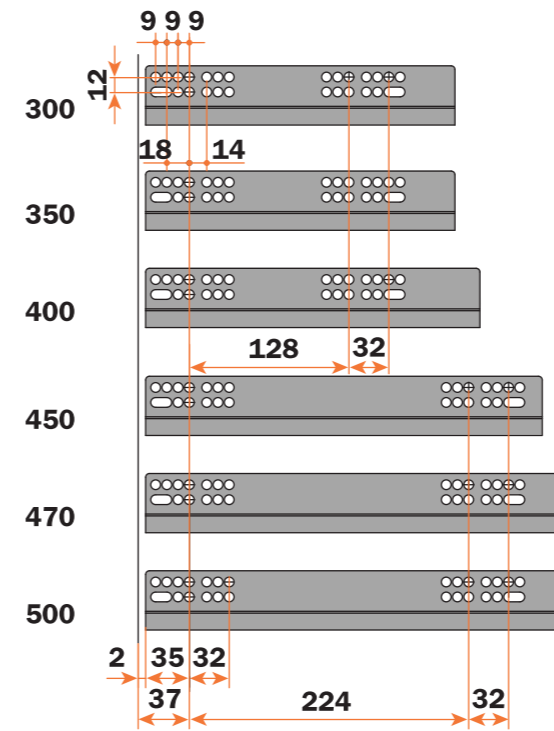

For the function Push is required a A value = 2,5 mm. This value is obtained by placing the runner at 37 mm from the edge of the cabinet.

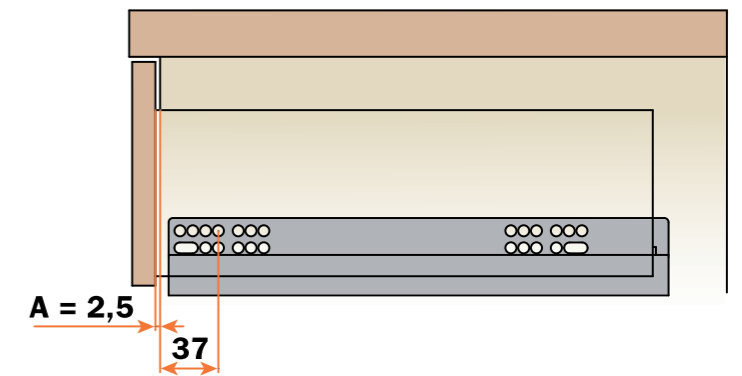

# Drawer setting

## Drawer setting: abbreviations

### Chest of drawers

SP = Thickness of the drawer

LN = Nominal runner length

PM = Depth of the cabinet

X = Internal width of the cabinet

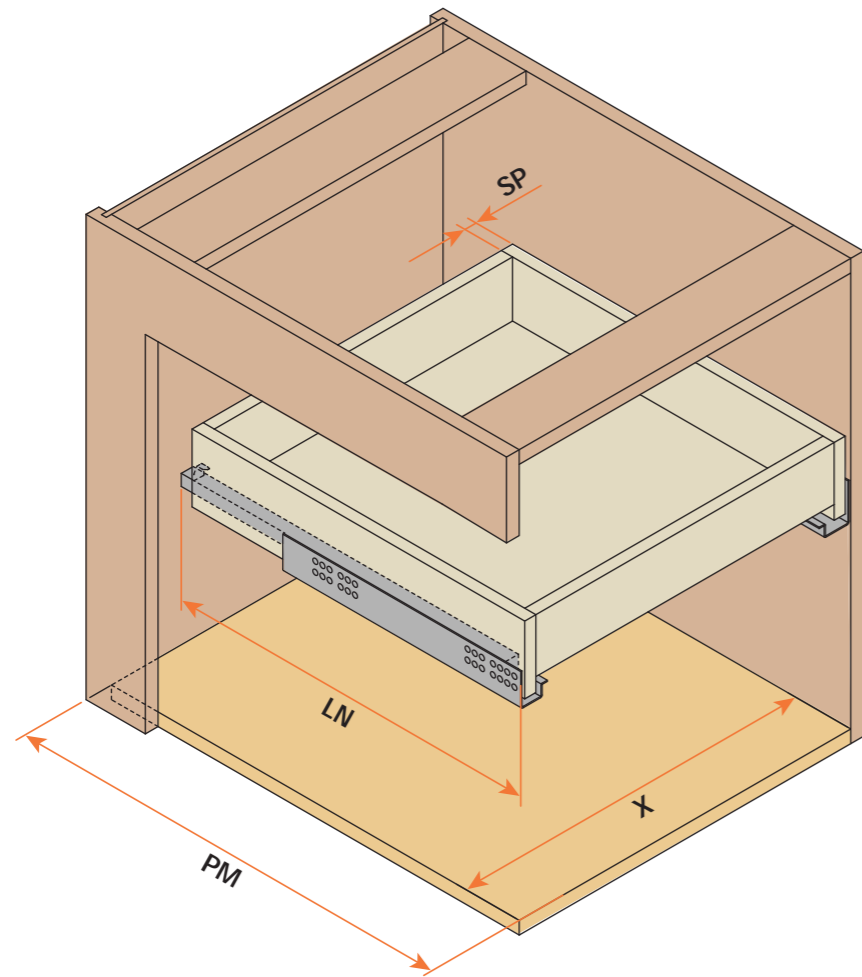

### Drawer dimensions

LC = Runner length - 10 mm

X - 41 = Internal width of the drawer

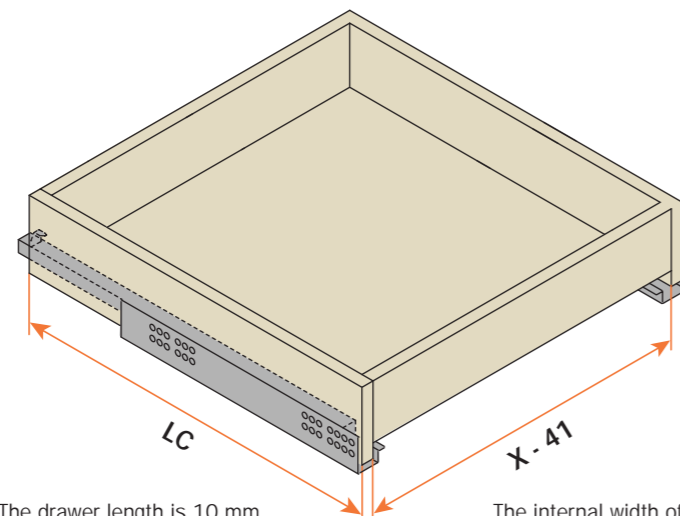

The drawer length is 10 mm shorter than the runner length

The internal width of the drawer is 41 mm less than the internal width of the cabinet

# Pin fix version - Drawer drilling

## Drawer drilling

Drawer with frontal (three-sided)  
(view from below)

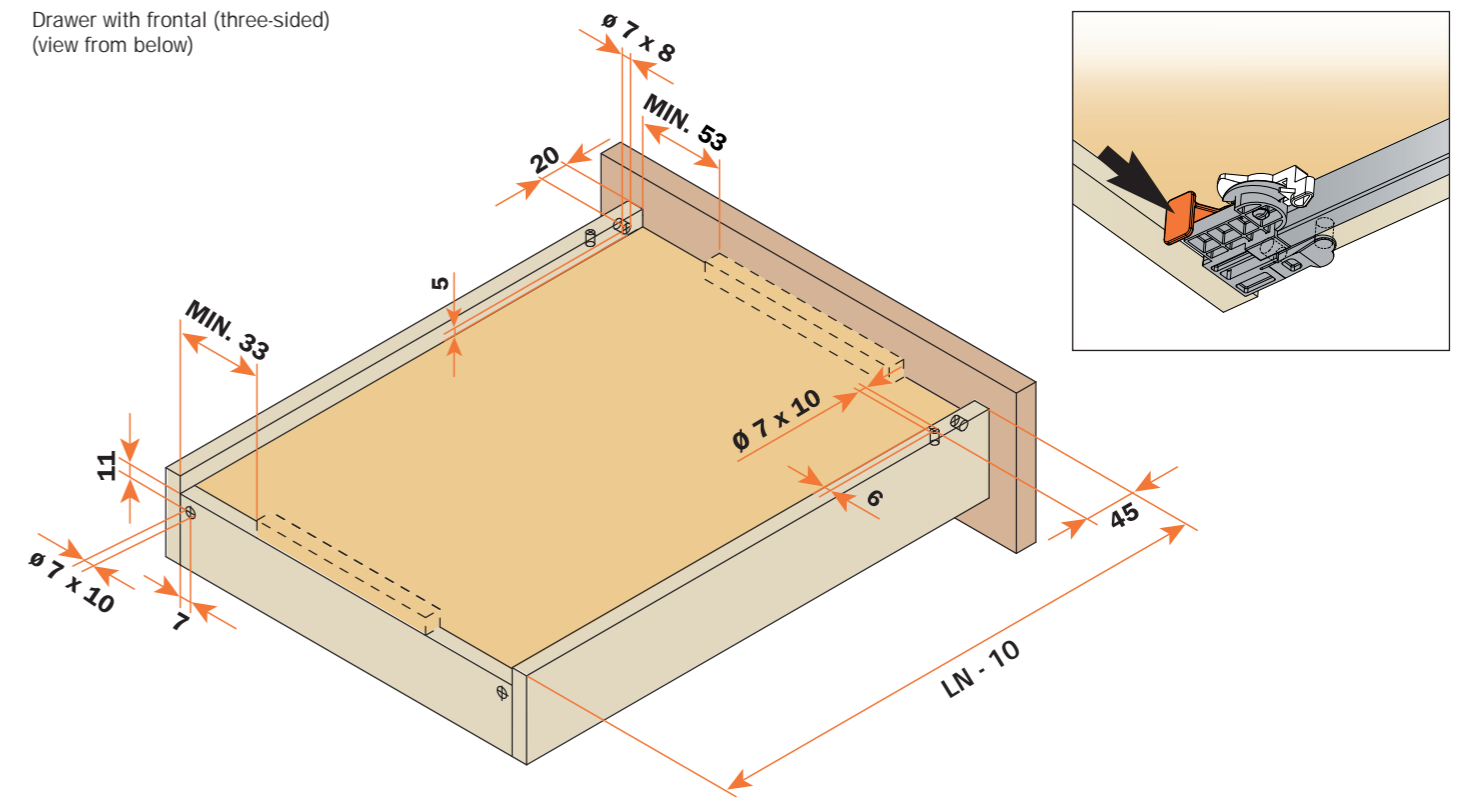

## Drawer drilling

Internal drawer (four-sided)  
(view from below)

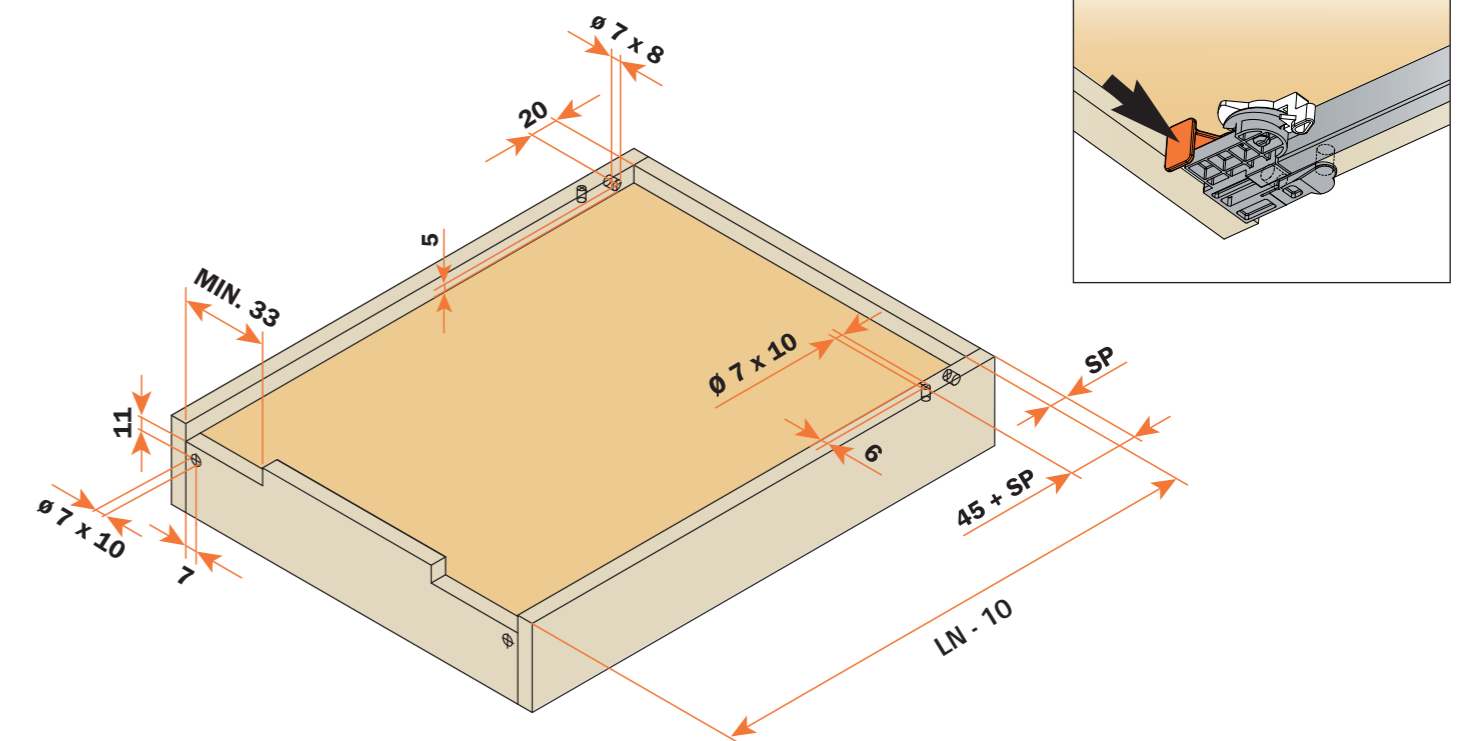

## Fixing of the drawer security pin

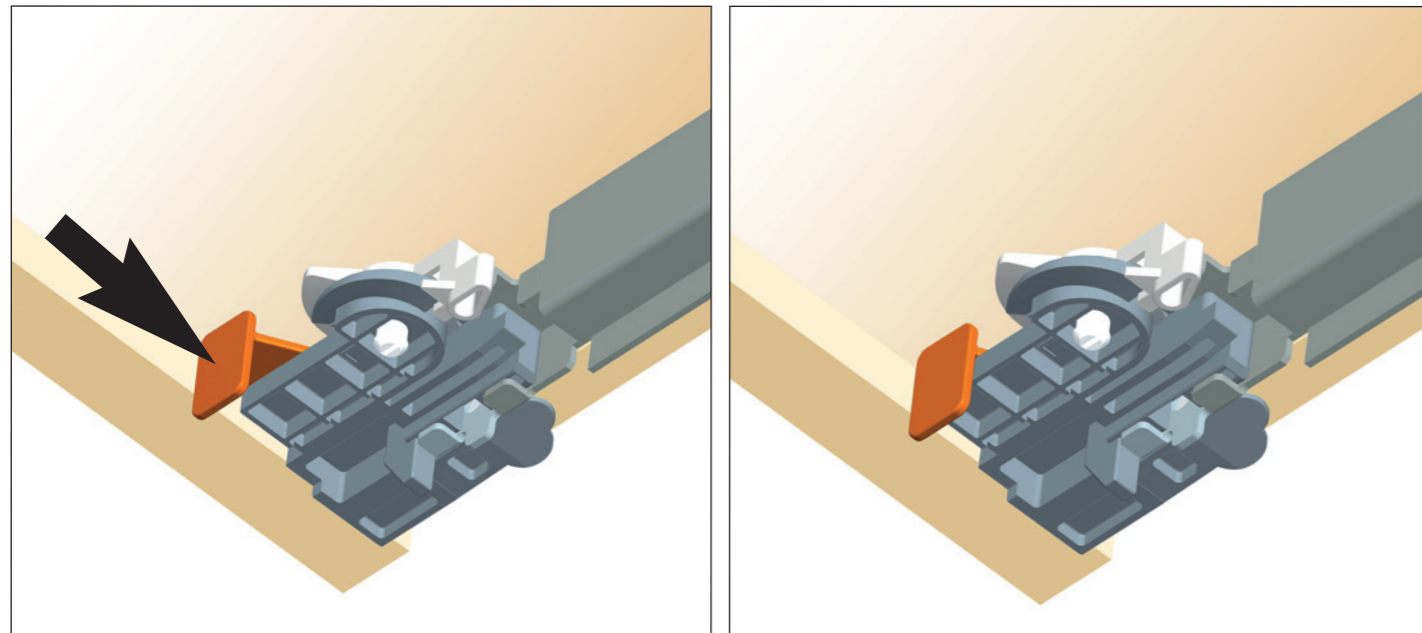

## Drawer adjustment

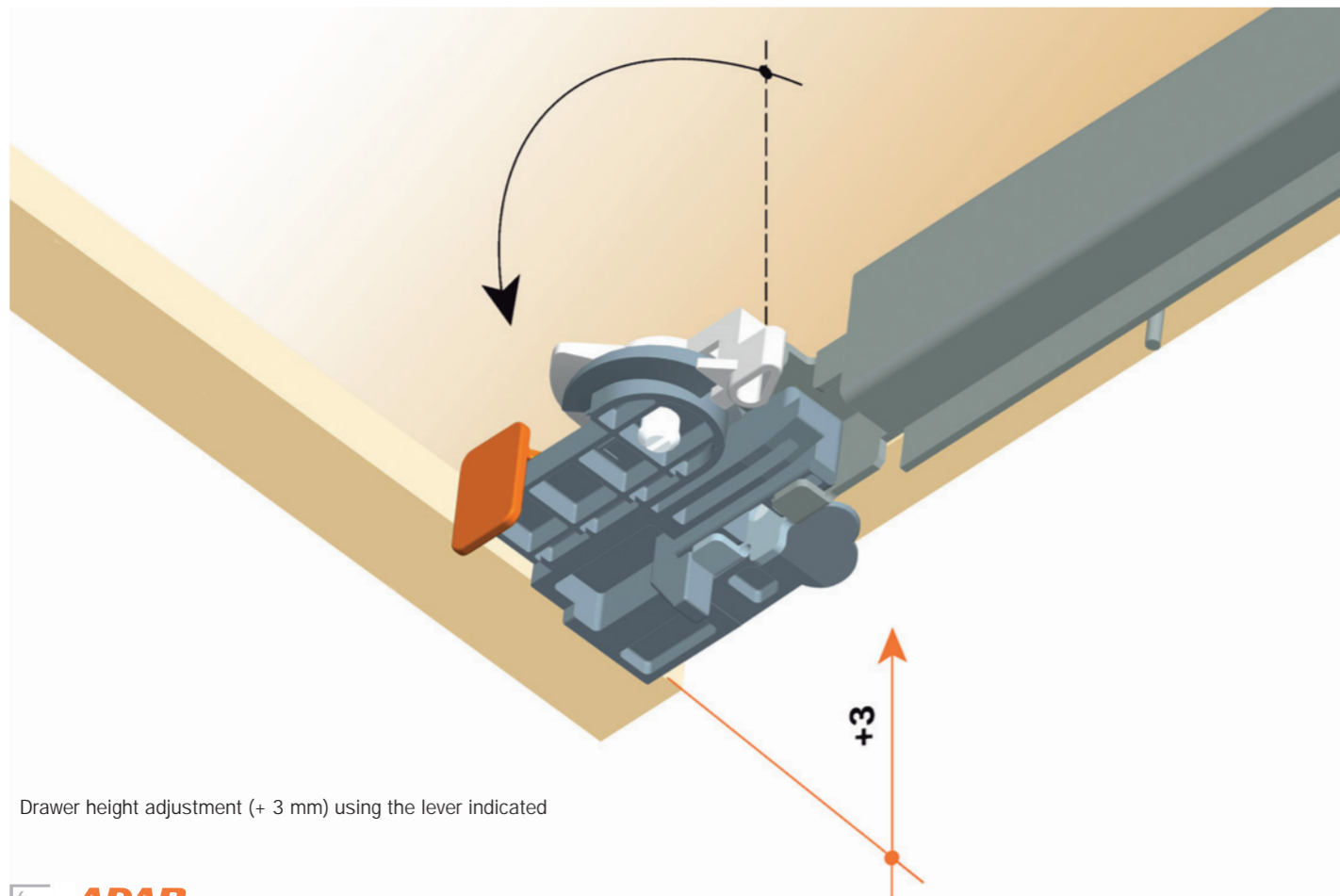

Drawer height adjustment (+ 3 mm) using the lever indicated

## INSTALLATION OF THE DRAWER

Extend the runners.



Place the drawer on the runners.



Close the drawer in order to locate it onto the locating pin of the runner.



Engage the drawer security pin.

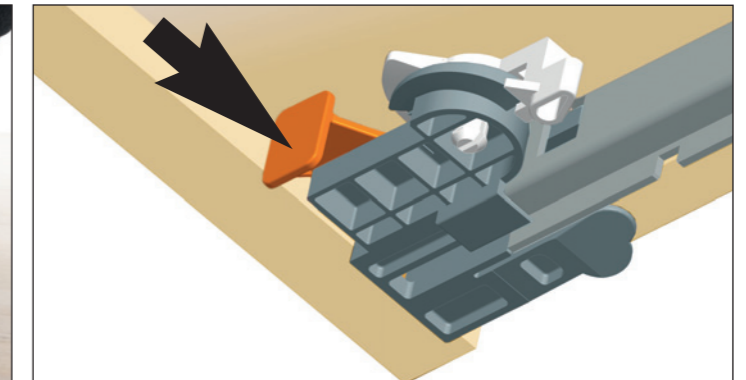

## REMOVAL OF THE DRAWER

Push or pull the frontal to open the drawer.



Open the drawer completely.



Disengage the drawer security pin.

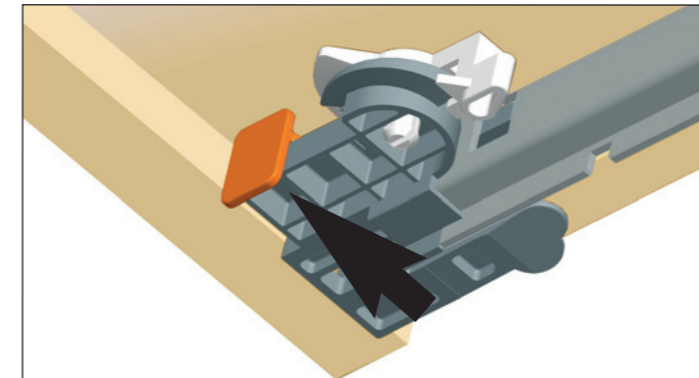

Lift and disengage the drawer.



# Clip version - Drawer drilling

## Drawer drilling

Drawer with frontal (three-sided)  
(view from below)

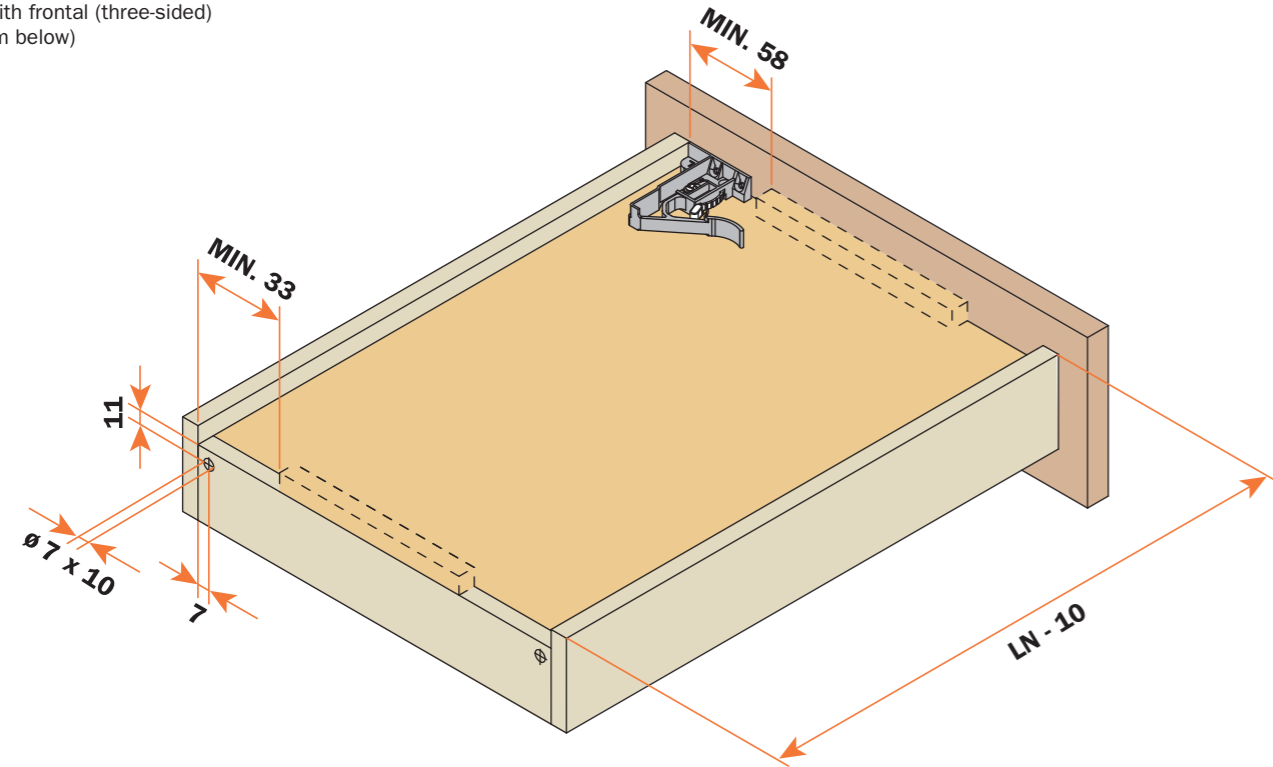

# Clip version - Technical information

## Fixing clip

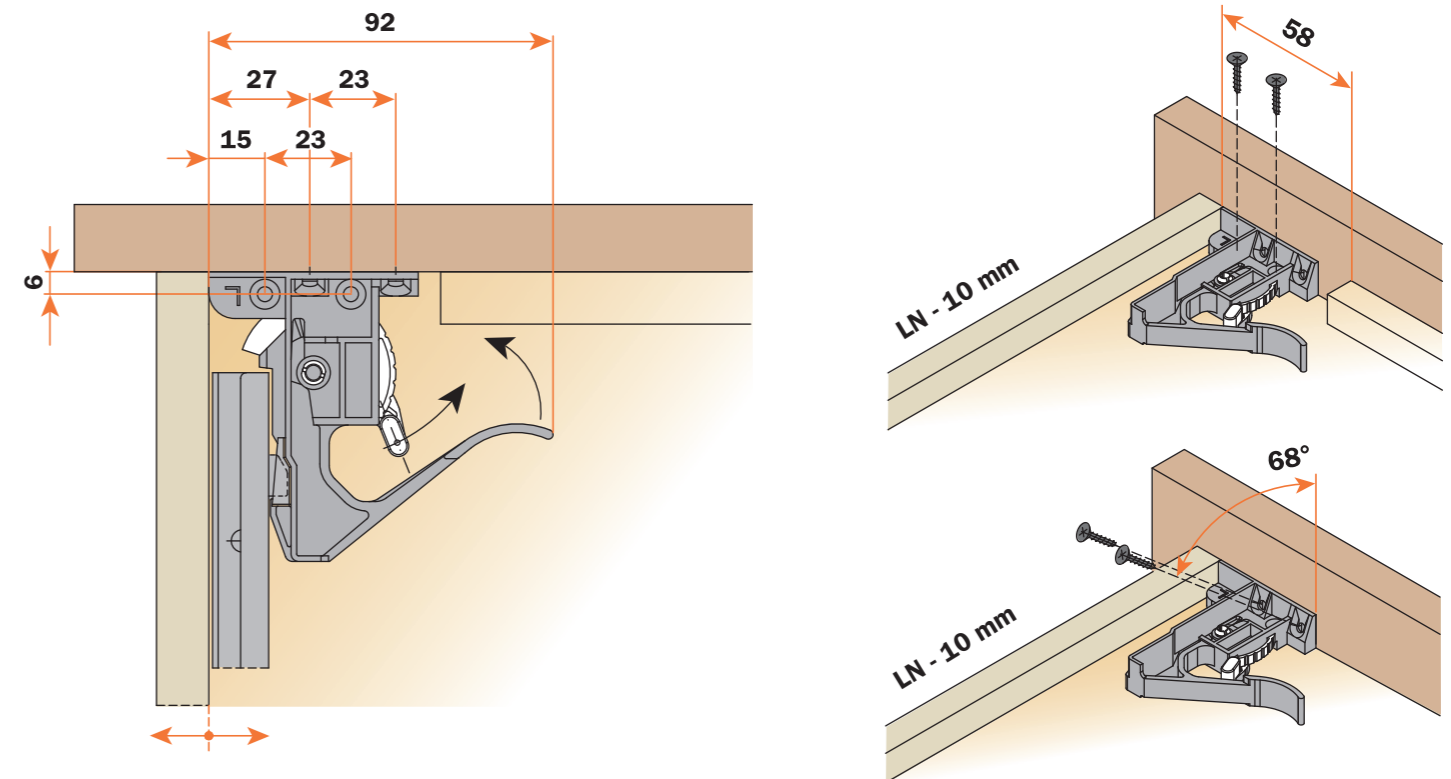

## Drawer drilling

Internal drawer (four-sided)  
(view from below)

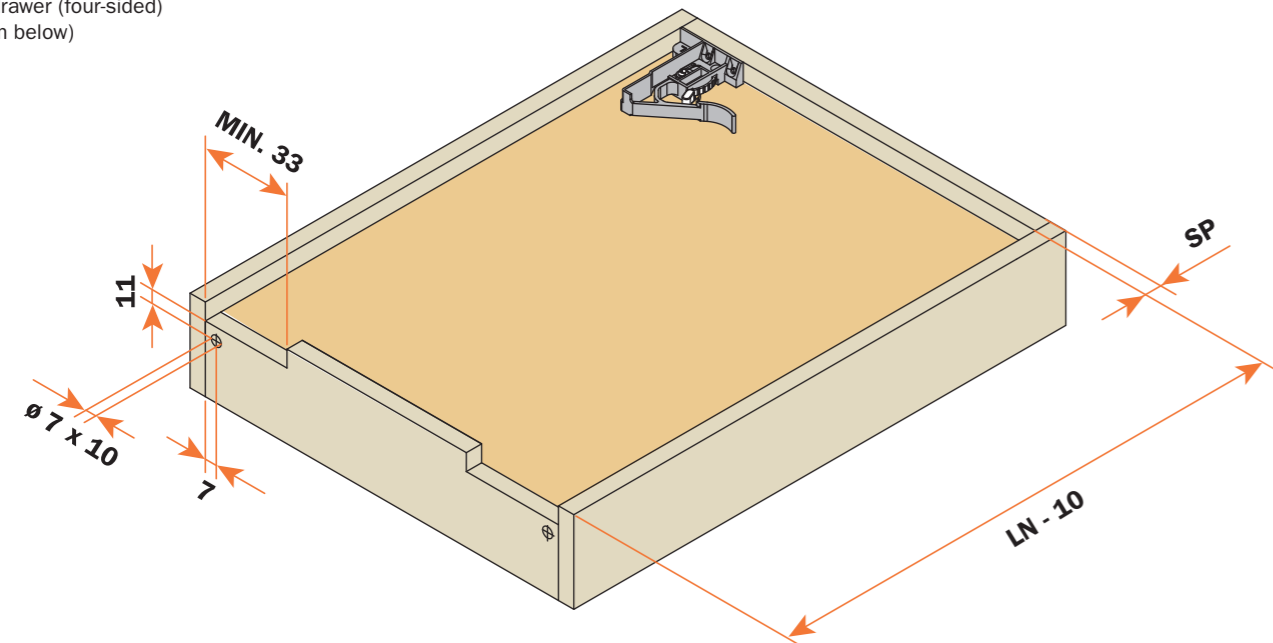

## Drawer adjustment

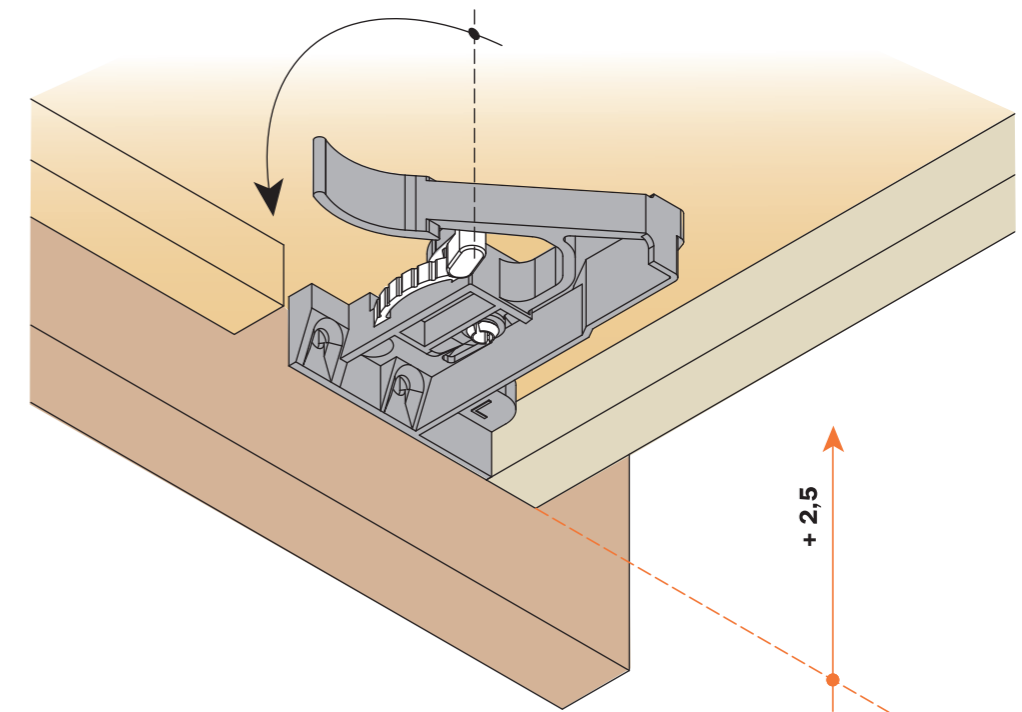

Drawer height adjustment (+ 2,5 mm) using the lever indicated

# Clip version - Installation and removal of the drawer

## INSTALLATION OF THE DRAWER

Extend the runners.



Place the drawer on the runners.



Close the drawer in order to engage the runners onto the clips.



## REMOVAL OF THE DRAWER

Push or pull the frontal to open the drawer.



Open the drawer completely.



Disengage the clips.



Pull the drawer forwards.



# Technical information

## Full-extension

Drawer length = extension

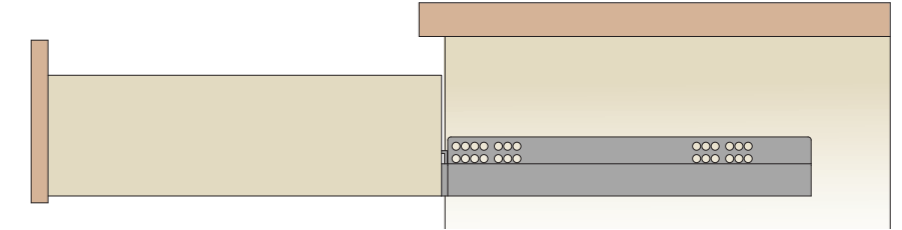

## Packing

### Industrial

#### CLIP VERSION

Box: 20 pcs. right  
Box: 20 pcs. left

Pallet: - length from 300 to 400 mm = 300 couples  
- length from 450 to 500 mm = 280 couples



#### PIN VERSION

Box: 20 pcs. right  
Box: 20 pcs. left

Pallet: - length from 300 to 400 mm = 300 couples  
- length from 450 to 500 mm = 280 couples



Clips should be ordered separately. Two boxes of 100 clips each. One box contains 100 right side clips and another box 100 left side clips.



## Part number composition

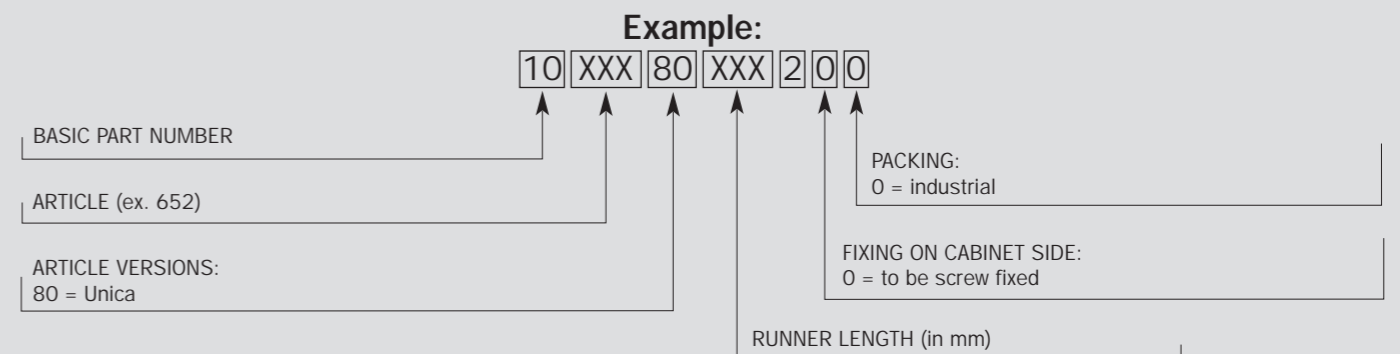



FULL-EXTENSION RUNNER SYSTEM FIXED TO THE DRAWER BY LOCATING PIN. THE PUSH SELF-OPENING SYSTEM FOR HANDLE LESS DRAWERS IS FULLY INTEGRATED INTO THE RUNNER. A SLIGHT PRESSURE ON THE DRAWER FRONTAL IS SUFFICIENT FOR THE DRAWER TO SELF-OPEN. THE SMOOVE DECELERATED CLOSING ACTION IS ALSO FULLY INTEGRATED INTO THE RUNNER.

#### Product features

- Safety system that secures the drawer to the runner.
- Drawer height adjustment (+3 mm).
- The drawer is maintained parallel with the cabinet side during opening.
- Drawer fixing without screws.
- Finish: bright zinc-plated.

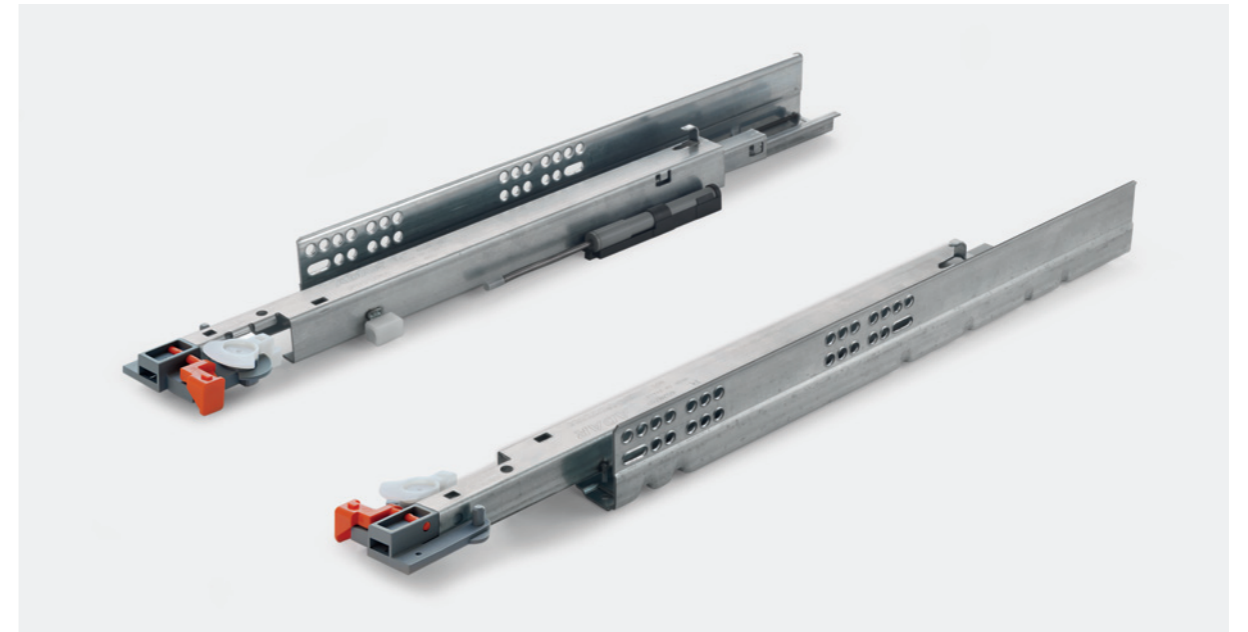

## Dimensions

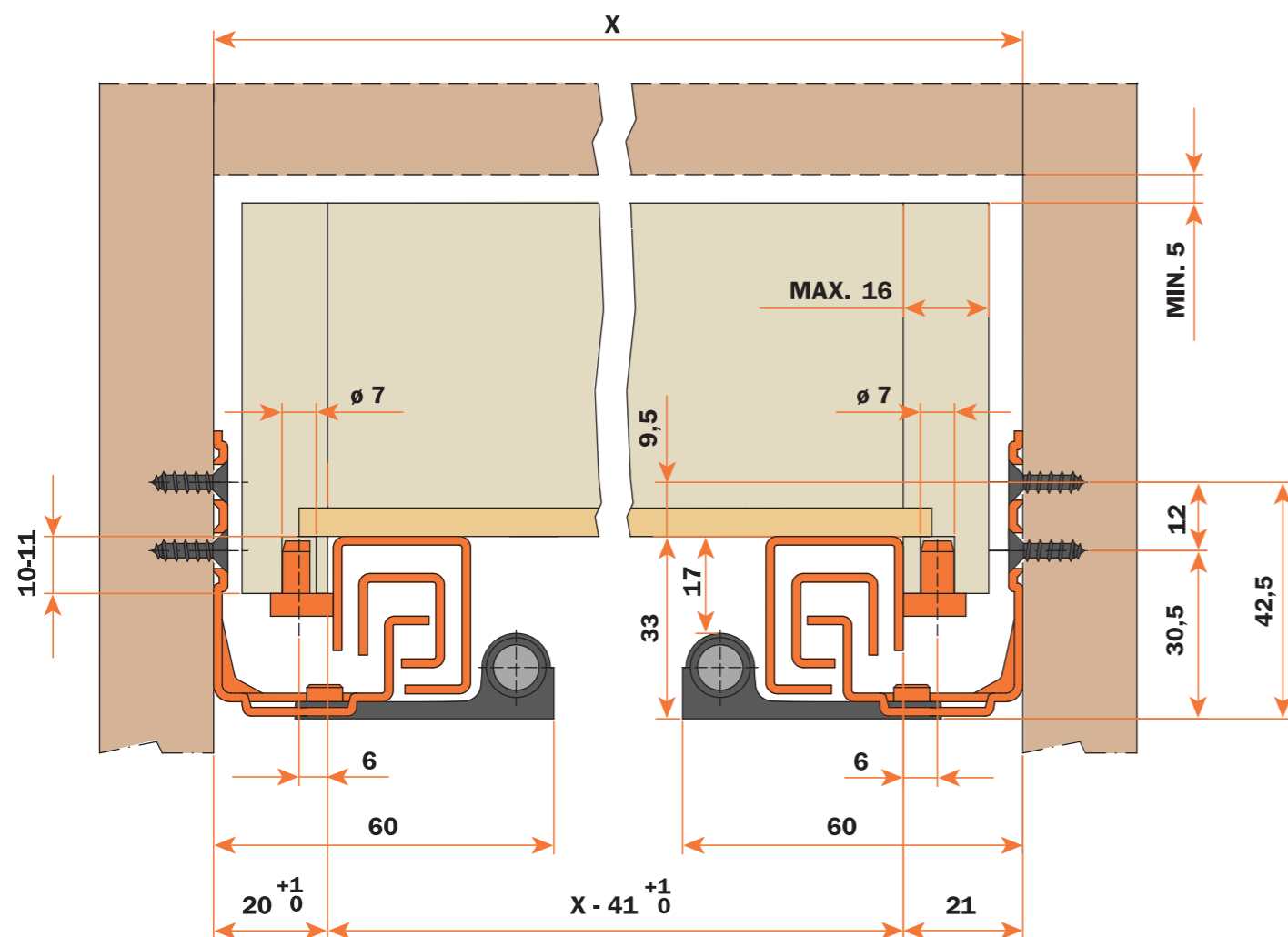

## Part number

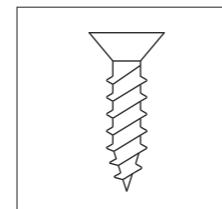

To be screw fixed  
Screw TSP ø 3,5 mm

BASIC PART NUMBER	RUNNER LENGTH (LN)	MIN. DEPTH OF THE CABINET (PM)
1 0 652 80 300 2 0 0	300	300
1 0 652 80 350 2 0 0	350	350
1 0 652 80 400 2 0 0	400	400
1 0 652 80 450 2 0 0	450	460
1 0 652 80 470 2 0 0	470	470
1 0 652 80 500 2 0 0	500	500



FULL EXTENSION RUNNER SYSTEM FIXED TO THE DRAWER BY CLIP. THE PUSH SELF OPENING SYSTEM FOR HANDLE LESS DRAWERS IS FULLY INTEGRATED INTO THE RUNNER. A SLIGHT PRESSURE ON THE DRAWER FRONTAL IS SUFFICIENT FOR THE DRAWER TOO SELF-OPEN. THE SMOVE DECELERATED CLOSING ACTION IS ALSO FULLY INTEGRATED INTO THE RUNNER.

**Product features**

- Safety system that secures the drawer to the runner.
- Drawer height adjustment (+2,5 mm).
- The drawer is maintained parallel with the cabinet side during opening.
- Finish: bright zinc-plated.



## Dimensions

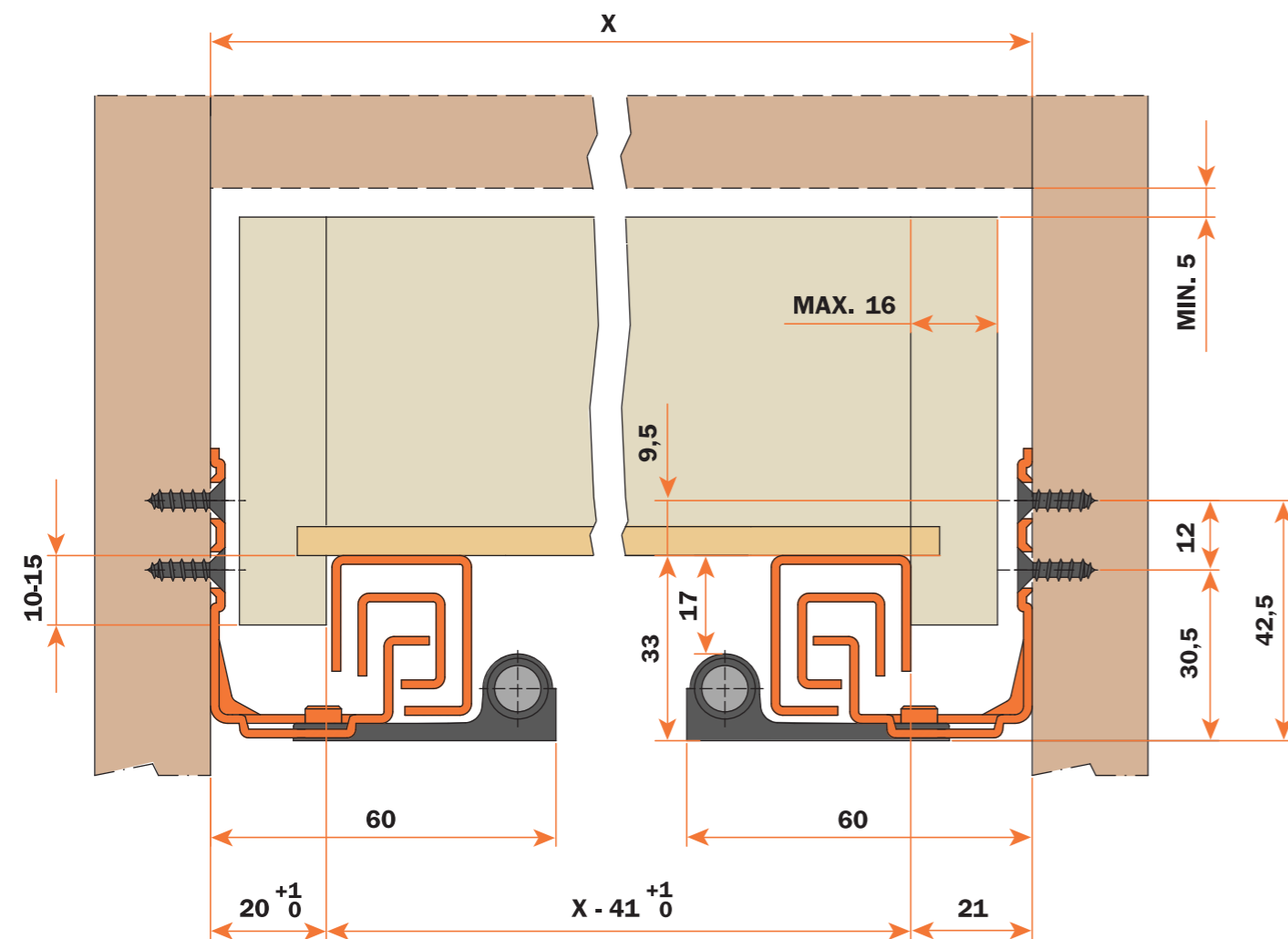

## Part number

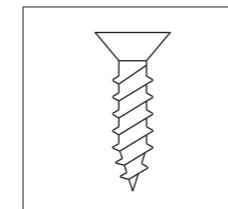

To be screw fixed  
Screw TSP ø 3,5 mm

BASIC PART NUMBER	RUNNER LENGTH (LN)	MIN. DEPTH OF THE CABINET (PM)
1 0 655 80 300 2 0 0	300	300
1 0 655 80 350 2 0 0	350	350
1 0 655 80 400 2 0 0	400	400
1 0 655 80 450 2 0 0	450	460
1 0 655 80 470 2 0 0	470	470
1 0 655 80 500 2 0 0	500	500

CLIP PART NUMBER
1 0 710 00 010 1 0 0



## **ADAR S.p.A.**

VIA ARISTIDE MERLONI, 11  
61030 CALCINELLI DI SALTARA (PU) ITALIA  
TEL. 0721 899800  
FAX 0721 897980  
adar@adar.it  
www.adar.it

### **ADAR IN DEUTSCHLAND**

DEUTSCHE SALICE GMBH  
RUDOLF-DIESEL-STR. 10  
POSTFACH 1154  
74382 NECKARWESTHEIM  
TEL. 07133 9807-0  
FAX 07133 9807-16  
info.salice@deutschesalice.de  
www.deutschesalice.de

### **ADAR IN DEUTSCHLAND**

DEUTSCHE SALICE GMBH  
VERKAUFSBÜRO NORD  
ENGERSTRASSE 147  
32051 HERFORD  
TEL. 05221 31056 - 31138  
FAX 05221 31198  
info.saliceherford@deutschesalice.de  
www.deutschesalice.de

### **ADAR EN FRANCE**

SALICE FRANCE S.A.R.L.  
ROUTE DE GOA ZAC LES 3 MOULINS  
06600 ANTIBES  
TEL. 0493 330069  
FAX 0493 330141  
info.salice@salicefrance.com  
www.salicefrance.com

### **ADAR IN THE UK**

SALICE UK LTD.  
KINGFISHER WAY  
HINCHINGBROOKE BUSINESS PARK  
HUNTINGDON CAMBS PE 29 6FN  
TEL. 01480 413831  
FAX 01480 451489  
info.salice@saliceuk.co.uk  
www.saliceuk.co.uk

### **ADAR IN U.S.A.**

SALICE AMERICA INC.  
2123 CROWN CENTRE DRIVE  
CHARLOTTE NC. 28227  
TEL. 704 8417810  
FAX 704 8417808  
info.salice@saliceamerica.com  
www.saliceamerica.com

### **ADAR IN CANADA**

SALICE CANADA INC.  
4025 SLADEVIEW CRESCENT  
UNIT # 7-9  
MISSISSAUGA, ONTARIO L5L 5Y1  
TEL. 905 8208787  
FAX 905 8207226  
info.salice@salicecanada.com  
www.salicecanada.com